

EC Type-Approval Certificate UK 2661 Revision 5

Issued by:

National Measurement Office
Notified Body Number 0126

In accordance with the requirements of the Non-Automatic Weighing Instruments Regulations 2000 (SI 2000/3236) which implement, in the United Kingdom, Council Directive 2009/23/EC, this EC type-approval certificate has been issued to:

A&D Instruments Ltd
24 Blacklands Way
Abingdon Business Park
Abingdon
Oxfordshire OX14 1DY
United Kingdom

in respect of a Class III, Non-Automatic Weighing Instrument designated the SK-1000WP, SK-2000WP, SK5000WP, SK10KWP, SK-20KWP or SK-30KWP and having the following characteristics:

Model	Max	Min (20 e)	e	Divisions
SK-1000WP	1000 g	10 g	0.5 g	2000
SK-2000WP	2000 g	20 g	1 g	2000
SK-5000WP	5000 g	40 g	2 g	2500
SK10KWP	10 kg	100 g	5 g	2000
SK-20KWP	20 kg	200 g	10 g	2000
SK-30KWP	30 kg	400 g	20 g	1500

The necessary data (principal characteristics, alterations, securing, functioning etc) for identification purposes and conditions (when applicable) are set out in the descriptive annex to this certificate.

This revision replaces previous versions of the certificate.

Issue Date: 8 January 2013
Valid Until: 12 November 2022
Reference No: T1128/0062

Signatory: P R Dixon
for Chief Executive



0135



**National
Measurement
Office**

Descriptive Annex

1 INTRODUCTION

The A&D SK-WP series of instruments are mains or battery powered, Class III, non-automatic weighing instruments, fitted with a combined semi-automatic zero setting and subtractive tare balancing device, and a semi-automatic calibration and gravity compensation device (see Figure 1).

2 DESCRIPTION

2.1 Construction

2.1.1 Mechanical

Main features:

- 280 mm x 270 mm metal lower-case unit supports the load cell and sensor unit. The unit also houses the main board, which incorporates the seven segment LCD display.
- Keypad consisting of two function keys.
- A CE-marked mains power adapter, providing an 8-9 V DC output to the weighing instrument.
- Load cell

The load cell is available in six different capacities:

- Max 1000 g, e = 0.5 g
- Max 2000 g, e = 1 g
- Max 5000 g, e = 2 g
- Max 10 kg, e = 5 g
- Max 20 kg, e = 10 g
- Max 30 kg, e = 20 g

2.1.2 Keyboard

The keyboard consists of two functional keys (see Figure 1):

- ON/OFF - switches the display on and off
- RE-ZERO - sets the display to zero. The re-zero key is a combined semi-automatic zero setting subtractive tare-balancing device.

2.1.3 Display

The seven segment LCD display provides five 2.5 cm high, 7 segment fields to display the weight value, and an additional field to display the units.

Up to 4 enunciators can be displayed, to indicate stable, polarity, net or zero. The STABLE indicator indicates when the reading is stable. The NET indicator indicates when NET weight is displayed when the tare function is used. The ZERO indicator

indicates when the scale zero is correct. The polarity indicator indicates that the reading is negative when illuminated and positive when not illuminated.

2.1.4 Circuitry

All signal processing and communications with the load cell are achieved from the control circuitry within the main unit.

2.2 **Operation**

2.2.1 Switch on

On power up the instrument displays all segments for a few seconds and the 0 will be displayed.

2.2.2 Automatic power-off function

If the unit is left on and the stable indicator is displayed, an automatic power-off function turns the power off after approximately five minutes. To disable this function the ON/OFF key must be pressed at the same time as the RE-ZERO key. P4-xx will be displayed. Release both keys and the scale returns to the weighing mode.

2.2.3 Initial zero setting

Initial zero setting is possible between $\pm 10\%$ of max capacity.

2.2.4 Zero tracking

Zero tracking operates between $\pm 2\%$ of maximum capacity. The maximum speed of tracking is 0.5 d per second.

2.2.5 Combined semi-automatic zero-setting and subtractive tare balancing device.

The subtractive tare and the semi-automatic zero devices are operated by the same function key, and are controlled by software.

Subtractive semi-automatic tare balancing facility is provided and there is prevention of use above Max when 'E' is indicated on the display.

The combined zero/tare key (labelled RE-ZERO) if the load is below 2% of maximum capacity initiates the zero-setting function, if the load is above 2% of maximum capacity the same key initiates the subtractive tare function.

2.2.6 Semi-automatic calibration and gravity compensation device

In calibration mode the instrument may be calibrated using a weight or by entering a local gravity value.

2.2.7 Over range

Loads greater than nine divisions above maximum capacity result in an error code shown as 'E' in the centre of the weight display. The stability enunciator is blanked for unstable loads.

3 TECHNICAL DATA

3.1 Power supply $230 \pm 10\%$ V AC 50 Hz providing an 8-9 V DC supply to the instrument.

4 PERIPHERAL DEVICES AND INTERFACES

4.1 Interfaces

There are no peripheral devices present.

5 SOFTWARE

The scale configuration and calibration parameters are stored in the EEPROM. The display indicates the software version number by, when power is off, press and hold RE-ZERO key and press POWER key. Release both keys to display software version. The software version will be in the format of "P4.xx".

6 APPROVAL CONDITIONS

6.1 Legends

6.1.1 The instrument bears the following legends (see Figure 2):

Max
Min
e =

6.1.2 The instrument shall bear the following legends:

CE mark
Verification mark
Green M
Class
Serial number
Manufacturers mark or name
Certificate number

6.1.3 The SK-WP series of instruments are not to be used for direct sales to the public.

7 LOCATION OF SEALS AND VERIFICATION MARKS

The data plate, green M sticker and the verification mark are mounted on the right hand side of the instrument (see Figure 2).

A wire and lead seal sealing the two entry ports on the bottom of the instrument prevent access to the load cell, main circuit board and calibration lock switch. (see Figure 3).

The wire and lead seal may have the mark of a verification officer, or alternatively, the manufacturers mark.

8 AUTHORISED ALTERNATIVES

8.1 Having an alternative manufacturer name of MeWa GmbH.

9 ILLUSTRATIONS

Figure 1 General View
Figure 2 Legends
Figure 3 Location of data plate
Figure 4 Sealing diagram

10 CERTIFICATE HISTORY

Issue No.	Date	Description
UK 2661	4 December 2002	Type approval first issued
UK 2661 Revision 1	19 April 2004	Revision 1 issued: Certificate issued in the name of MeWa GmbH
UK 2661 Revision 2	28 November 2005	Revision 2 issued: Change to section 2.1.1 to permit any CE-marked mains adaptor to be used.
UK 2661 Revision 3	24 August 2006	Revision 3 issued: Certificate issued in the name of A&D Instruments. Creation of section 6.1.
UK 2661 Revision 4	13 November 2012	Revision 4 issued: Addition of SK-30KWP model, section 2.1.1 revised to add additional load cell capacity and certificate renewed for a further period of 10 years.
UK 2661 Revision 5	08 January 2013	Revision 5 issued: Reference number on page 1 corrected. Model number corrected.

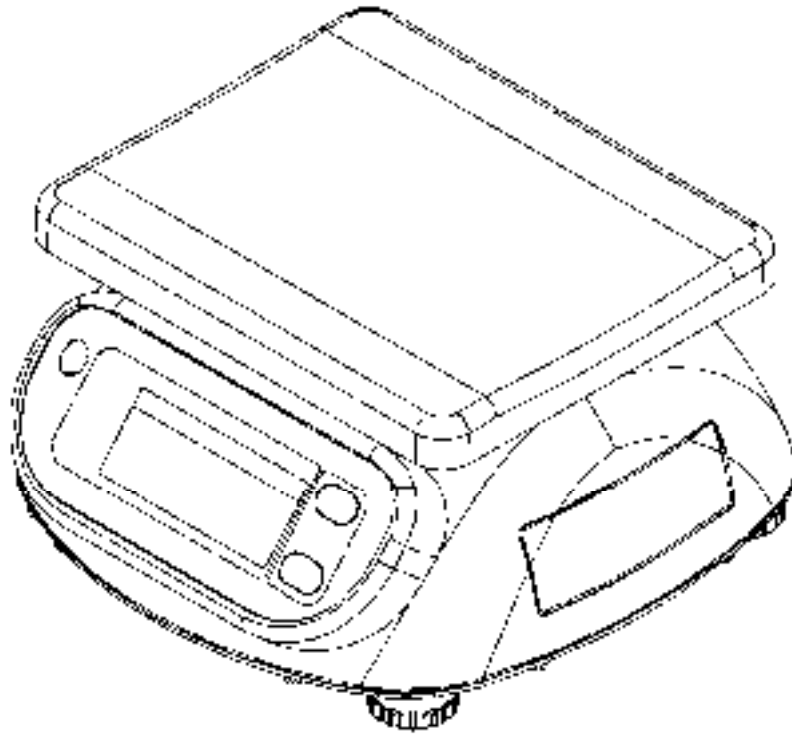

Figure 1 General View

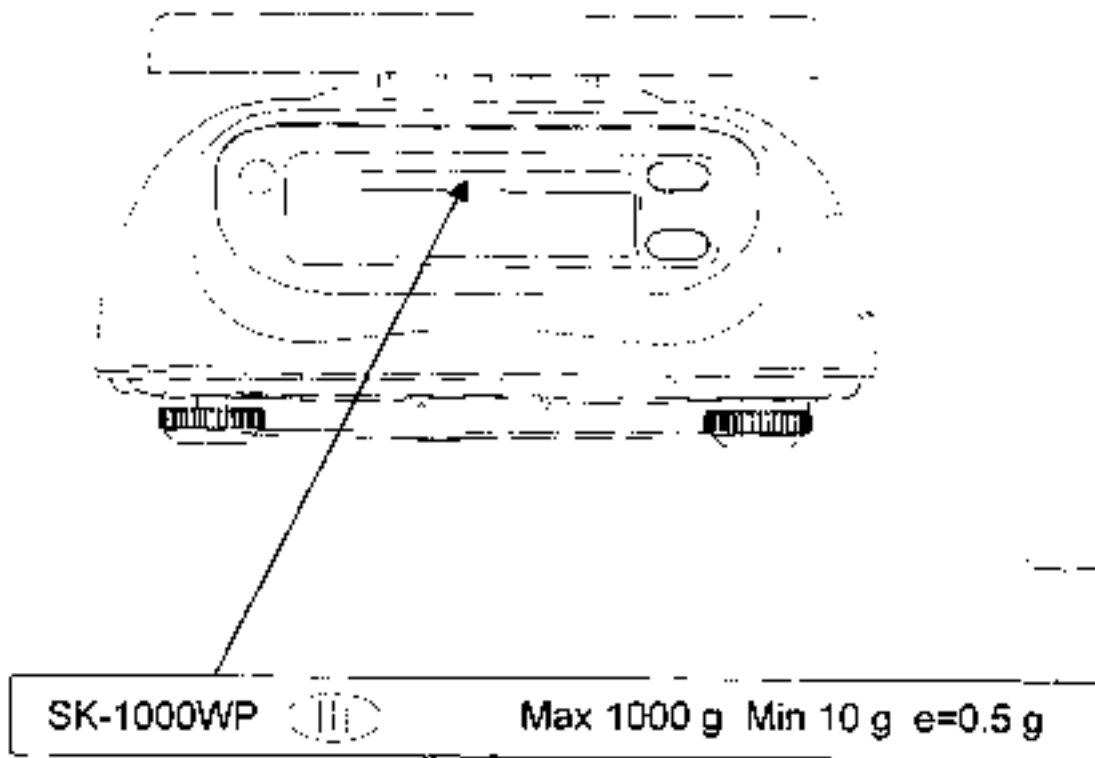

Figure 2 Legends

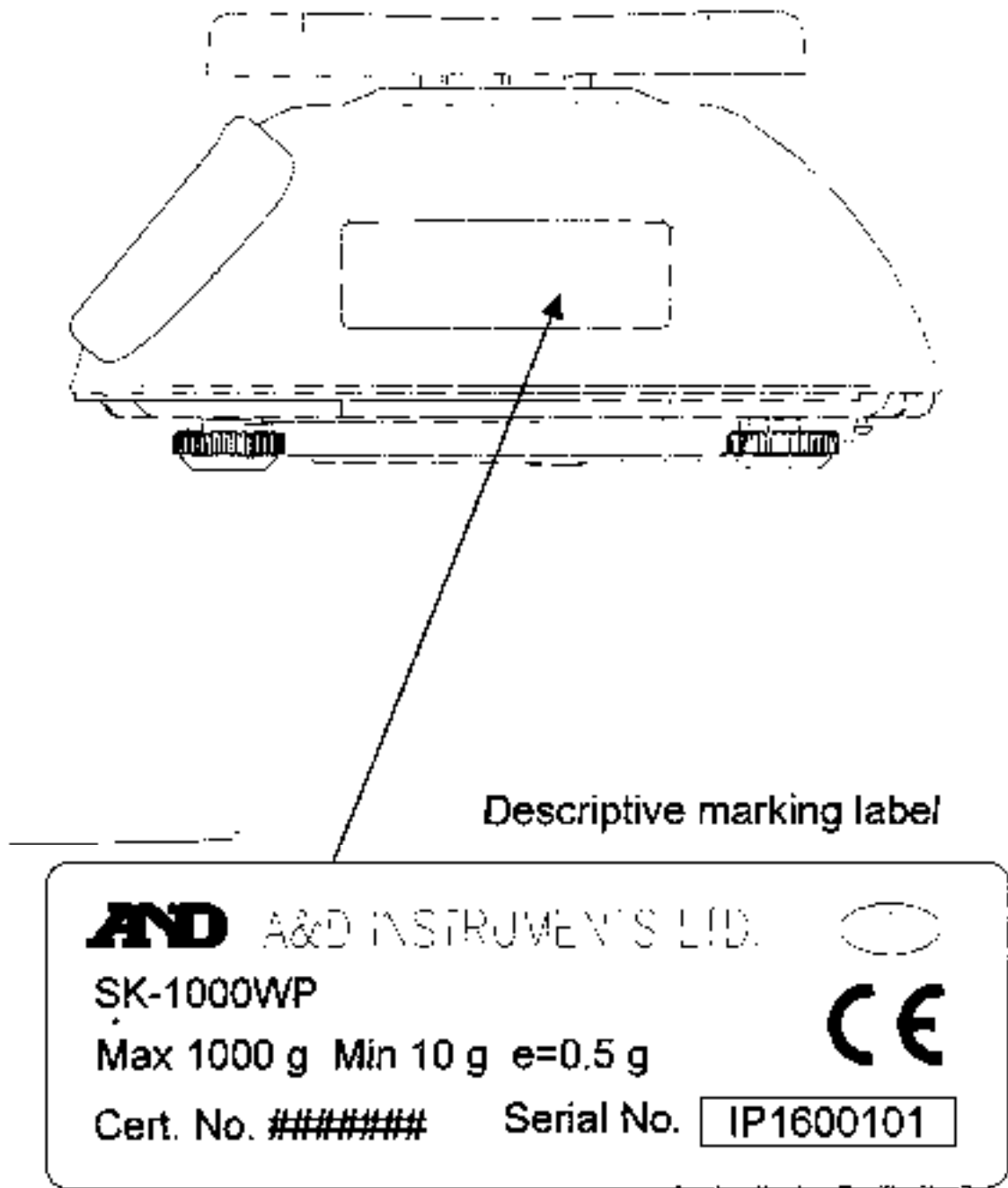

Figure 3 Location of data plate and CE marking

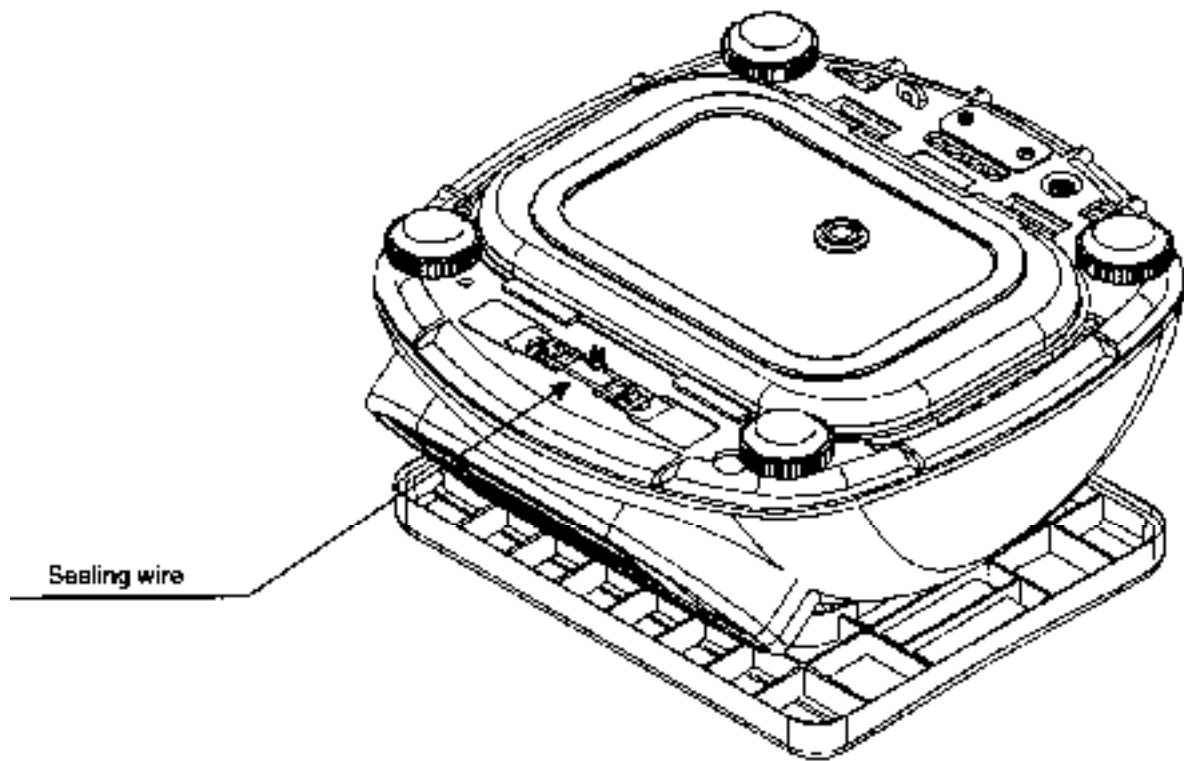

Figure 4 Sealing diagram